

2014
FORD CHASSIS FOR
SHUTTLE BUS
APPLICATIONS



- E-350/E-450 Super Duty Cutaway Chassis
- F-450/F-550 Super Duty Chassis Cab
- F-650 Super Duty Chassis Cab

COMMERCIAL
TRUCK





FORD Has The
RIGHT CHASSIS
To Fit Your
Transportation Needs.

E-350/E-450 SUPER DUTY CUTAWAY CHASSIS

PEP Code	Body Code	2014 Model			Engine Code	Transmission Code*	SRW/DRW	GVWR Code	GVWR (lbs.)
		Model	WB	Engine					
780A	E3F	E-350	138" WB	5.4L Gas	99L	44T	SRW	20X	10,050
780A	E3F	E-350	138" WB	6.8L Gas	99S	44T	SRW	20X	10,050
780A	E3F	E-350	158" WB	5.4L Gas	99L	44T	SRW	20X	10,050
780A	E3F	E-350	158" WB	6.8L Gas	99S	44T	SRW	20X	10,050
780A	E3F	E-350	138" WB	5.4L Gas	99L	44T	DRW	20Y	11,500
780A	E3F	E-350	138" WB	6.8L Gas	99S	44T	DRW	20Y	11,500
780A	E3F	E-350	158" WB	5.4L Gas	99L	44T	DRW	20Y	11,500
780A	E3F	E-350	158" WB	6.8L Gas	99S	44T	DRW	20Y	11,500
780A	E3F	E-350	158" WB	5.4L Gas	99L	44T	DRW	20C	12,500
780A	E3F	E-350	158" WB	6.8L Gas	99S	44T	DRW	20C	12,500
780A	E3F	E-350	176" WB	5.4L Gas	99L	44T	DRW	20C	12,500
780A	E3F	E-350	176" WB	6.8L Gas	99S	44T	DRW	20C	12,500
782A	E4F	E-450	158" WB	5.4L Gas	99L	44T	DRW	205	14,000
782A	E4F	E-450	176" WB	5.4L Gas	99L	44T	DRW	205	14,000
782A	E4F	E-450	158" WB	6.8L Gas	99S	44T	DRW	20F	14,500
782A	E4F	E-450	176" WB	6.8L Gas	99S	44T	DRW	20F	14,500

* 44T = 5-speed Automatic Overdrive TorqShift® Transmission with Tow/Haul Mode



E-SERIES SUPER DUTY CUTAWAY

Wide Range of Available Gross Vehicle Weight Ratings (GVWR).

2014 FORD E-350 SUPER DUTY CUTAWAY For SHUTTLE BUS Builders.

Shuttle Bus Prep Package (47B)

This package, available on E-350 and E-450 Cutaways, is designed for shuttle bus manufacturers and includes the following:

- High Series Exterior Upgrade Package (18A) which includes Front Chrome Bumper, Chrome Grille, Dual Beam Headlamps w/fixed lens
- Manual Pedestals, seats not included (21W)
- Power Windows and Locks Group - includes one touch down driver window (903) N/A with RH door delete (60X)
- Frame pucks (isolators - included when spacers not ordered)
- Front Max. GAWR on E-450
- Engine block heater
- Front license plate bracket (153)
- Exterior Mirror Delete (54F)
- Heavy Duty 155-Amp Alternator (63M).
 - Can upgrade to Extra Heavy Duty 225-Amp Alternator (63N) with either engine

Deletes:

- Front headliner/Front dome lamp/Front vinyl floor covering
- Note - Front vinyl floor covering (162) may be added back*

E-350/E-450 CUTAWAY

Dimension 'A' =
68.5" w/138" or 158" WB
50.5" w/176" WB

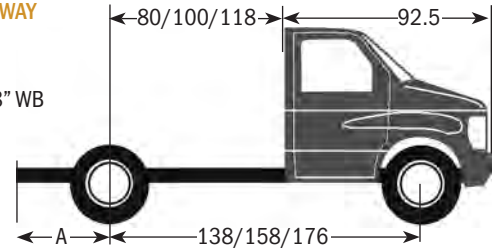

CNG/LPG Fuel Capability - Gaseous Engine Prep Package (91G)
required for conversion to CNG or LPG operation. See Dealer for details.

ITEM	E-350 SUPER DUTY CUTAWAY CHASSIS w/47B			E-450 SUPER DUTY CUTAWAY CHASSIS w/47B	
WHEELBASE (in.)	138	158	176	158	176
MAX. GVW RATINGS (lbs.)	10,050 (SRW) 11,500 (DRW)	10,050 (SRW) 12,500 (DRW)	12,500 (DRW)	14,000 (DRW w/5.4L Gas) 14,500 (DRW w/6.8L Gas)	
MAX. FRONT GAWR (lbs.)	5,000			5,000	
AXLE, FRONT (lbs.)	5,000 Twin-I-Beam IFS			5,000 Twin-I-Beam IFS	
AXLE, REAR (lbs.)	7,800 (SRW); 8,500 (DRW), Dana Full Floating			9,600, Dana Full Floating	
AXLE RATIO	4.10 (Std.); 4.10 LS (Opt.)			4.56 (Std.); 4.56 LS (Opt.)	
BRAKES, SERVICE	Power, Self Adjusting Hydro-Boost Assist (DRW), Vacuum Boost (SRW) Four Wheel Disc with Four Wheel Anti-Lock			Power, Self Adjusting, Hydro-Boost Assist Four Wheel Disc with Four Wheel Anti-Lock	
BRAKE, PARKING	Rear Axle Mounted Drum-In-Hat Type, Foot Operated			Rear Axle Mounted Drum-In-Hat Type, Foot Operated	
ELECTRICAL - ALTERNATOR (GAS ENGINE)	155-Amp Heavy Duty (Std.) 225-Amp (Opt.)			155-Amp Heavy Duty (Std.) 225-Amp (Opt.)	
- BATTERY (GAS ENGINE)	12-Volt, 650-CCA/72-Amp Hr (Std.) Dual 78-Amp Hr HD (Opt.)			12-Volt, 650-CCA/72-Amp Hr (Std.) Dual 78-Amp Hr HD (Opt.)	
ENGINE/HORSEPOWER/TORQUE	5.4L Triton® V8 - Flex Fuel Capable (Std.) 255 HP @ 4,500 RPM/350 lb.-ft. Torque @ 2,500 RPM 6.8L Triton® V10 (Opt.) 305 HP @ 4,250 RPM/420 lb.-ft. Torque @ 3,250 RPM			5.4L Triton® V8 - Flex Fuel Capable (Std.) 255 HP @ 4,500 RPM/350 lb.-ft. Torque @ 2,500 RPM 6.8L Triton™ V10 (Opt.) 305 HP @ 4,250 RPM/420 lb.-ft. Torque @ 3,250 RPM	
FRAME	Single Channel 36,000 PSI 5.73 Cu. In. Section Modulus			Single Channel 36,000 PSI 6.4 Cu. In. Section Modulus	
FUEL TANK	40.0 Gallon (140L) Aft-of-Axle (Std.) 55.0 Gallon (208L) Aft-of-Axle (Opt. w/158" DRW only)			55.0 Gallon (208L) Aft-of-Axle (Std.) 40.0 Gallon (140L) Aft-of-Axle (Opt.)	
SHOCK ABSORBERS	1.38" HD Gas-Type, Front and Rear			1.38" HD Gas-Type, Front and Rear	
SPRINGS, FRONT COIL TYPE (lbs.)	4,200 Max. (SRW) 4,600 Max. (DRW)	5,000 Max.	5,000 Max.	5,000 Max.	
SPRINGS, REAR (lbs.)	7,310 (SRW); 8,500 (DRW) Multi-Leaf/Single Stage			9,600 Multi-Leaf/Single Stage	
STABILIZER BAR, FRONT (in.)	1.0 (SRW); 0.91 (DRW) diameter			0.91 diameter	
STABILIZER BAR, REAR (in.)	1.125 (DRW) diameter			1.125 diameter	
STEERING	HD Power			HD Power	
TIRES	(4) LT245/75R16E (SRW); (6) LT225/75R16E (DRW)			(6) LT225/75R16E (Std.)	
WHEELS, 8-HOLE DISC	(4) 16.0x7, Gray (Std.), White (Opt.) (SRW) (6) 16.0x6, White 4 Hand Hole (DRW) (4) 16.0x7 Forged Aluminum (Opt.) (SRW)			(6) 16.0x6, White 4 Hand Hole	
TRANSMISSION	5-Speed, TorqShift® Automatic Overdrive (Std.) Tow/Haul Mode (Std.) Auxiliary Transmission Oil Cooler (Std.)			5-Speed, TorqShift® Automatic Overdrive (Std.) Tow/Haul Mode (Std.) Auxiliary Transmission Oil Cooler (Std.)	

SRW - Single Rear Wheel

DRW - Dual Rear Wheel

2014 FORD F-450/F-550 SUPER DUTY CHASSIS CAB

For SHUTTLE BUS Builders.

Wheelbase Choices

F-450/F-550 Super Duty Regular Cab Chassis models are available in 4 wheelbase lengths and 4 CA dimensions.

Selection of Gross Vehicle Weight Ratings (GVWRs) and Payload

Shuttle bus customers and builders can select GVWRs ranging from 16,500 lbs. to 19,500 lbs. and payloads ranging from 9,951 to 12,666 lbs. (Regular Cab).

Choice of Powertrains

Two responsive and dependable powertrains are available.

- The tough and reliable 6.8L Triton® V10 Gasoline engine mated to the durable TorqShift® 5-speed automatic transmission with overdrive: The TorqShift automatic includes Tow/Haul Mode which helps reduce gear hunting, improves power delivery and uses engine braking to help control vehicle speed when descending hills.
- The 6.7L Power Stroke® V8 Turbo Diesel engine offers great performance and fuel economy. The engine is mated to the TorqShift® Heavy-Duty 6-Speed SelectShift Automatic™ double overdrive transmission with Tow/Haul Mode which smoothly and automatically enables exhaust braking and reduces brake wear.

Airbag Delete Option for Front Entry Buses

In order to assist the builder with a front entry door, Ford offers a Frontal Passenger and Side Airbags/Curtains Delete Option (valid with Fleet FIN Code)-557 (XL).

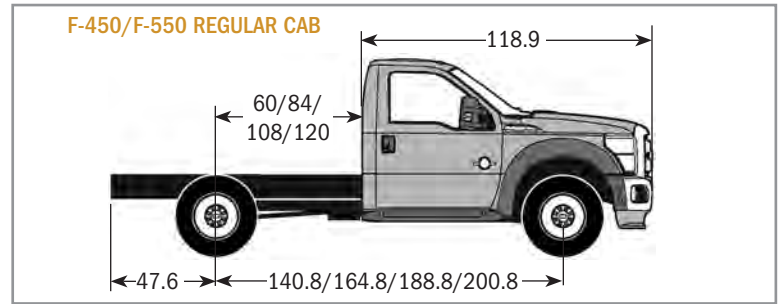

CNG/LPG Fuel Capability – Gaseous Engine Prep Package (98G) required for conversion to CNG or LPG operation. See Dealer for details.

ITEM	F-450 SUPER DUTY CHASSIS CAB	F-550 SUPER DUTY CHASSIS CAB
CAB CONFIGURATION	Regular Cab	Regular Cab
WHEELBASE (in.)	141, 165, 189, 201	141, 165, 189, 201
MAX. GVW RATINGS (lbs.)	16,500 (DRW)	19,500 (DRW)
AXLE, FRONT (lbs.)	7,000 Dana Super 60	7,000 Dana Super 60
AXLE, REAR (lbs.)	12,000 Dana S110	13,660 w/17,500 and 18,000 GVWR 14,706 w/19,500 GVWR
AXLE RATIO	Gas: 4.88 (Std.), 4.88 LS (Opt.); Diesel: 4.10 (Std.), 4.10 LS (Opt.)	Gas: 4.88 (Std.), 4.88 LS (Opt.); Diesel: 4.10 (Std.), 4.10 LS (Opt.)
BRAKES, SERVICE	Power, Self-Adjusting Hydro-Boost Assist	Power, Self-Adjusting Hydro-Boost Assist
	Four Wheel Disc with Four Wheel Anti-lock	Four Wheel Disc with Four Wheel Anti-lock
BRAKE, PARKING	Rear Axle Mounted, 9.5" Drum-in-Hat Type, Foot Operated	Rear Axle Mounted, 9.5" Drum-in-Hat Type, Foot Operated
ELECTRICAL - ALTERNATOR	175-Amp Heavy Duty (Std. Gas) 200-Amp Extra Heavy Duty (Std. Diesel) Dual 357-Amp (Opt. Diesel)	175-Amp Heavy Duty (Std. Gas) 200-Amp Extra Heavy Duty (Std. Diesel) Dual 357-Amp (Opt. Diesel)
- BATTERY	12-Volt, 750-CCA/78-Amp Hr (Std. Gas) Two 12-Volt 750-CCA (1,500-CCA Total) 78-Amp Hr (Std. Diesel)	12-Volt, 750-CCA/78-Amp Hr (Std. Gas) Two 12-Volt 750-CCA (1,500-CCA Total) 78-Amp Hr (Std. Diesel)
ENGINE/HP/TORQUE	6.8L Triton® 3V SEFI V10 (Std.) 362 HP @ 4,750 RPM/457 lb.-ft. Torque @ 3,250 RPM 6.7L Power Stroke® V8 Turbo Diesel (Opt.) 300 HP @ 2,800 RPM/660 lb.-ft. Torque @ 1,600 RPM	6.8L Triton® 3V SEFI V10 (Std.) 362 HP @ 4,750 RPM/457 lb.-ft. Torque @ 3,250 RPM 6.7L Power Stroke® V8 Turbo Diesel (Opt.) 300 HP @ 2,800 RPM/660 lb.-ft. Torque @ 1,600 RPM
FRAME	Single Channel, 36,000 PSI, Ladder Type 10.1 or 17.2 cubic inches SM, Based on Wheelbase and Payload Package	Single Channel, 36,000 PSI, Ladder Type 10.1 or 17.2 cubic inches SM, Based on Wheelbase and Payload Package
FUEL TANK	40 Gallon (Std.); Dual 40 Gallon Aft-of Axle and 28 Gallon Mid-ship (Opt. with 6.7L Diesel)	40 Gallon (Std.); Dual 40 Gallon Aft-of Axle and 28 Gallon Mid-ship (Opt. with 6.7L Diesel)
SHOCK ABSORBERS	1.38" Dia. HD Gas-type, Front and Rear	1.38" Dia. HD Gas-type, Front and Rear
SPRINGS, FRONT COIL TYPE (lbs.)	4,800 to 7,000 (Computer Assigned)	4,800 to 7,000 (Computer Assigned)
SPRINGS, REAR (lbs.)	12,000 Multi-Leaf, Single Stage Main Plus Auxiliary	13,660 to 15,000 Multi-Leaf, Single Stage Main Plus Auxiliary
STABILIZER BAR, FRONT (in.)	1.26	1.26
STABILIZER BAR, REAR (in.)	1.06	1.06
STEERING	Power (Includes Steering Damper)	Power (Includes Steering Damper)
TIRES	225/70Rx19.5G BSW All-Season (Std.) 225/70Rx19.5G BSW Traction (4 Traction on Rear and 2 A/S on Front (Opt.); 225/70Rx19.5G BSW Max Traction 4x4) (4 Traction on Rear and 2 Traction on Front (Not Recommended for Over the Road)	225/70Rx19.5G BSW All-Season (Std.) 225/70Rx19.5G BSW Traction (4 Traction on Rear and 2 A/S on Front (Opt.); 225/70Rx19.5G BSW Max Traction 4x4) (4 Traction on Rear and 2 Traction on Front (Not Recommended for Over the Road)
WHEELS	(6) 19.5" x 6" RW Argent Painted Steel (Std. w/XL, XLT)	(6) 19.5" x 6" RW Argent Painted Steel (Std. w/XL, XLT)
TRANSMISSION	TorqShift® 5-Spd. Overdrive w/Tow Haul Mode; (Std. w/6.8L V10) TorqShift® 6-Speed SelectShift™ Overdrive w/Tow/Haul Mode & Integrated Automatic Exhaust Braking (Std. w/6.7L V8 Diesel)	TorqShift® 5-Spd. Overdrive w/Tow Haul Mode; (Std. w/6.8L V10) TorqShift® 6-Speed SelectShift™ Overdrive w/Tow/Haul Mode & Integrated Automatic Exhaust Braking (Std. w/6.7L V8 Diesel)

2015 FORD F-650 SUPER DUTY CHASSIS CAB For SHUTTLE BUS Builders.

GASOLINE ENGINE

The Right Chassis

F-650 Super Duty Straight Frame offers GVWRs up to 29,000 lbs.

260" Wheelbase

The 260" wheelbase is designed for shuttle bus and RV applications.

Ford 6.8L V10 Gas Power

Ford 6.8L V10 Triton® 3-valve gas engine is available and is mated to the tough and durable TorqShift® 6-speed double overdrive transmission. The 6.8L engine is rated at 362 horsepower @ 4,750 RPM and 457 lb.-ft. of torque @ 3,250 RPM.

CNG/LPG Fuel Capability - Conversion to CNG or LPG operation requires 99D Engine Code. See Dealer for details.

Ford TorqShift® 6-Speed Automatic Double Overdrive

Heavy Duty transmission features 3.97 first gear to get moving.

Comfort and Convenience

- XL and XLT trim levels offer comfort for driver and passengers.
- Power windows with one-touch-down feature on driver's side delivers an unexpected level of convenience. One-touch-up on XLT only.
- A low side window belt line helps improve road visibility on the vehicle's sides.

The Ideal Chassis for Medium Duty Shuttle Bus Applications

A 'work ready' suggested specification list has been developed for shuttle bus builders (see pg. 7). Many other options and specifications are also available as shown below.

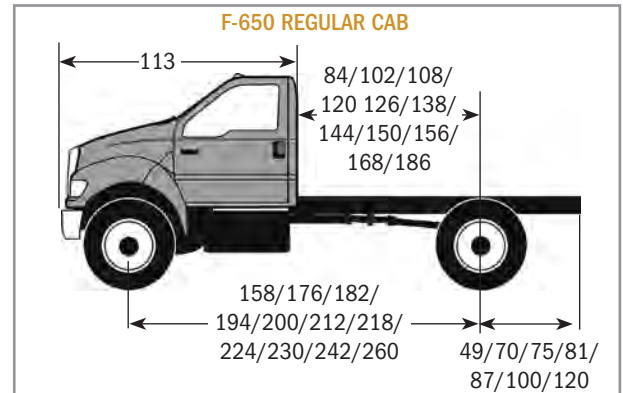

ITEM

F-650 SUPER DUTY GAS ENGINE CHASSIS CAB

ITEM	F-650 SUPER DUTY GAS ENGINE CHASSIS CAB
CAB CONFIGURATION	Regular Cab
WHEELBASE (in.)	158, 176, 182, 194, 200, 212, 218 224, 230, 242, 260
MAX. GVW RATINGS (lbs.)	29,000
AXLE, FRONT (lbs.)	8,500 (Std.); 10,000 (Opt.)
AXLE, REAR (lbs.)	17,500 (Std.); 19,000 (Opt.)
AXLE RATIO	5.13 to 7.17 Single-Speed Rear Axle
BRAKES, SERVICE (Standard)	Power, Hydraulic, Automatic Adjusting, Full Power Four-Wheel Disc with Four-Wheel Anti-lock
BRAKE, PARKING (Standard)	12" x 3" Rear Axle Mounted, Bosch DSSA Type
BRAKES, SERVICE (Optional)	Power, Full Air, Automatic Adjusting Four-Wheel Disc with Four-Wheel Anti-lock System
BRAKE, PARKING (Optional)	Spring Parking Brake Chambers Mounted Front of Rear Axle
ELECTRICAL - ALTERNATOR	177-Amp - 2,495 Watt (Std.)
- BATTERY	One 950-CCA (STD.)
ENGINE/HP/TORQUE - GAS	6.8L Triton® 3V V10, 362 HP @ 4,750 RPM
FRAME	Single Channel, 50,000 PSI (Std.)
FUEL TANK	42 Gal. (Std.) up to 60 Gal. Capacity (Opt.)
SHOCK ABSORBERS	Double Acting Front (Std.); Rear (Opt.)
SPRINGS, FRONT TYPE (lbs.)	8,500 (Std.), 10,000 (Opt.) Parabolic Taper-leaf
SPRINGS, REAR (lbs.)	17,500 (Std.), 15,500 (Opt.), 20,000 (Opt.) Vari-Rate Multi-leaf Incl. 4500 Rubber Aux.
SPRINGS, FRONT AUXILIARY	Rubber
STEERING	Integral Power Steering
TIRES	10R 22.5F 12PR (Std.); 225/70R19.5G 12PR (Opt.)
WHEELS	10-Hole 22.5"x7.5" Steel Disc (Std.); 8-Hole 19.5"x6.75" Steel Disc (Opt.)
TRANSMISSION - GAS	6-Speed TorqShift® Automatic



Metric conversion - To obtain information in kilograms, multiply the pounds by .45; to obtain information in kilometers, multiply the miles by 1.6; to obtain information in centimeters, multiply the inches by 2.54.

2015 FORD F-650 SUPER DUTY CHASSIS CAB For SHUTTLE BUS Builders.

DIESEL ENGINE

The Right Chassis

F-650 Super Duty Straight Frame offers GVWRs up to 29,000 lbs.

260" Wheelbase

The 260" wheelbase is designed for shuttle bus and RV applications, An exhaust to the end of the frame is available.

Cummins® 6.7L Power

The 6.7L Cummins ISB 200 HP diesel engine is standard on all F-650 models. Ten different horsepower/torque ratings are available.

Allison® Automatic Transmission

All F-650 diesel chassis cabs can be equipped with an Allison automatic transmission. Allison PTS (Pupil Transportation/Shuttle) Series transmissions provide reliable performance and economical maintenance for shuttle bus fleets.

Comfort and Convenience

- XL and XLT trim levels offer comfort for driver and passengers.
- Power windows with one-touch-down feature on driver's side delivers an unexpected level of convenience. One-touch-up on XLT only.
- A low side window belt line helps improve road visibility on the vehicle's sides.
- Available overhead gauge cluster with oil temperature and hour meter.

The Ideal Chassis for Medium Duty Shuttle Bus Applications

A 'work ready' suggested specification list has been developed for shuttle bus builders (see page 7). Many other options and specifications are also available as shown below.

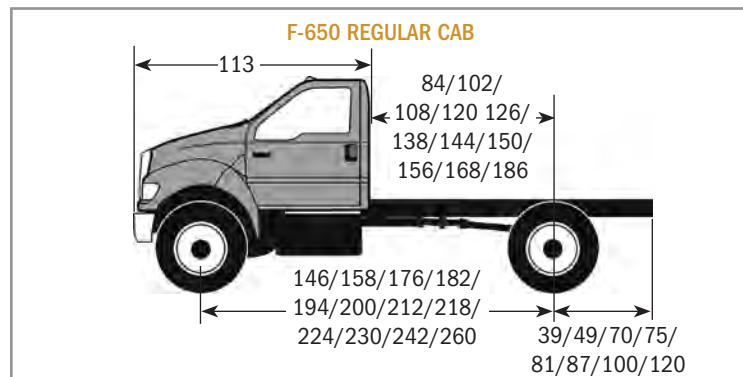

ITEM F-650 SUPER DUTY DIESEL ENGINE CHASSIS CAB Also Available With Gas Engine. See Your Dealer For Details.

CAB CONFIGURATION	Regular Cab
WHEELBASE (in.)	158, 176, 182, 194, 200, 212, 218 224, 230, 242, 260
MAX. GVW RATINGS (lbs.)	29,000
AXLE, FRONT (lbs.)	8,500 (Std.); 10,000 (Opt.)
AXLE, REAR (lbs.)	17,500 (Std.); 19,000 (Opt.)
AXLE RATIO	2.64 to 7.17 Single-Speed Rear Axle
BRAKES, SERVICE (Standard)	Power, Hydraulic, Automatic Adjusting, Full Power Four-Wheel Disc with Four-Wheel Anti-lock
BRAKE, PARKING (Standard)	12" x 3" Rear Axle Mounted, Bosch DSSA Type
BRAKES, SERVICE (Optional)	Power, Full Air, Automatic Adjusting, Full Power Four-Wheel Disc with Four-Wheel Anti-lock System
BRAKE, PARKING (Optional)	Spring Parking Brake Chambers Mounted Front of Rear Axle
ELECTRICAL - ALTERNATOR	210-Amp - 2,835 Watt (Std.) 240-Amp - 3,240 Watt (Opt.) 320-Amp - 4,320 Watt (Opt.)
- BATTERY	Two 700-CCA (1,400-CCA Total) (Std.) Three 700-CCA (2,100-CCA Total) (Opt.) Two 950-CCA (1,900-CCA Total) (Opt.) Three 950-CCA (2,850-CCA Total) (Opt.)
ENGINE/HP/TORQUE - DIESEL	Cummins (Std.) 200 HP @ 2,300 RPM (Std.) to 325 HP @2,600 (Opt.)
FRAME	Single Channel, 50,000 PSI (Std.)
FUEL TANK	45 Gal. (Std.) up to 145 Gal. Capacity Dual Tanks (Opt.)
MIRRORS	Sail-mounted, Manual Folding, Heated and Motorized Glass
SHOCK ABSORBERS	Double Acting Front (Std.); Rear (Opt.) (Incl. w/Air Rear Suspension);
SPRINGS, FRONT TYPE (lbs.)	8,500 (Std.), 10,000 (Opt.) Parabolic Taper-leaf
SPRINGS, REAR (lbs.)	18,500 (Std.), 15,500 (Opt.), 20,000 (Opt.) Vari-Rate Multi-leaf Incl. 4500 Rubber Aux. 18,500 or 20,000 (Opt.) Air Suspension
SPRINGS, FRONT AUXILIARY	Rubber
STEERING	Integral Power Steering
TIRES	11R 22.5G 14PR (Std.); 225/70R19.5 12PR (Opt.)
WHEELS	10-Hole 22.5"x7.5" Steel Disc (Std.); 8-Hole 19.5"x6.75" Steel Disc (Opt.)
TRANSMISSION - DIESEL	6- or 7-Speed Manual; 5- or 6-Speed Allison Automatic

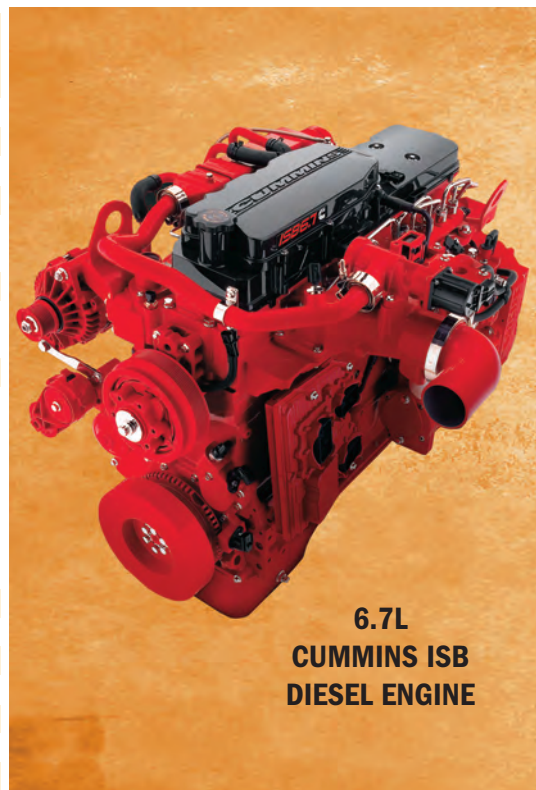

M Metric conversion - To obtain information in kilograms, multiply the pounds by .45; to obtain information in kilometers, multiply the miles by 1.6; to obtain information in centimeters, multiply the inches by 2.54.

2015 FORD F-650 SUPER DUTY CHASSIS CAB For SHUTTLE BUS Builders.

2015 F-650 Super Duty Recommended Shuttle Bus Builder Specs

The options list below reflect the equipment most often selected by Shuttle Bus Body Builders and Operators for buses built on a Ford Medium Duty Chassis. Additional options are available.

- F-650 Regular Cab XLT
- 260" Wheelbase
- Cummins 6.7L ISB, Allison 2200 (PTS Series) and 6,14:1 Axle Ratio
 - Geared Speed: 75 MPH
 - Cruise Speed: 68 MPH @ 2,300 RPM
 - Startability: 22.0% in 1st Gear
- 25,999 lbs. GVWR
- 186" CA



CODE	ITEM	DESCRIPTION
F6F	F-650	Regular Cab-Straight Frame
---	260 (inches)	Wheelbase
YZ	Paint	Oxford White
20Y	GVWR	Special - Limited to 25,999 Lbs.
534	Frame	29,000 Lbs. Max. Frame Rating (Std.)
43N	Front Axle	Dana E-1002F - 10,000 Lbs. Rating
61C	Front Springs	10,000 Lbs. Rating
61Y	Front Springs	Auxiliary
---	Wheel Seals	Front - Stemco
47L	Rear Axle	Dana S17-140 -19,000 Lbs. Rating - Includes GenTech Quiet Gears
X6A	Axle Ratio	6:14:1
68E	Rear Suspension	Air Suspension -18,500 Lbs. Rating
68Z	Control	Rear Suspension Dump Valve
---	Wheel Seals	Rear - Stemco
67J	Brakes	Hydraulic - Quadraulic; Includes Bosch DSSA Parking Brake
62B	Compressor	Cummins 18.7 CFM
62R	Drain Valve	Automatic
99C	Engine	Cummins 6.7L Diesel - 240 HP; 560 Lb.-Ft. Torque
41G	Block Heater	Phillips 120-Volt/750-Watt
17D	Alternator	320-Amp Leece-Neville
425	Emissions	50 State
44E	Transmission	Allison 2200 6-Speed PTS
91A	Exhaust	Right Side Horizontal - Exit Front of Rear Wheels
65N	Fuel Tank	65 Gallon Mounted Left Side

CODE	ITEM	DESCRIPTION
682A	PEP	XLT Preferred Equipment Package
882	Seat	Driver - 30% Width - Air Suspension - Steel Gray Cloth
85R	Seat	Passenger - 30% Width - Steel Gray Cloth
85X	Seat Delete	Delete passenger seat when right hand door is to be removed
63G	Battery	Two 12-Volt, 950-CCA Temporary Mounted
16V	Voltmeter	Mounted in Overhead Pod
17H	Hourmeter	Mounted in Overhead Pod
962	DRL	Daytime Running Lights
55X	Tail Lights	Delete
54P	Mirror	Sail Mounted - Manual, Folding, Heated Glass and Motorized Glass (Including Convex)
647	Wheels-Front	22.5X7.5 10-Hole Steel
667	Wheel-Rear	22.5X7.5 10-Hole Steel
TJD	Front Tires	Goodyear 255/80R22.5G XZE
RJD	Rear Tires	Goodyear 255/80R22.5G XZE
86G	DEF Tank	5 Gallon Mounted LH Rail, Back of Cab in SuperCab Position
21A	PDI	Pre-delivery Inspection at the Factory

OTHER AVAILABLE OPTIONS

CODE	ITEM	DESCRIPTION
43B	Front Axle	Dana I-100SG - 10,000 Lbs. Rating
477	Rear Axle	Meritor MS-19-145 -19,000 Lbs. Quiet Ride Gears
60A/608	Lube	Rear Axle - Synthetic
62D	Air Dryer	Bendix AD/IP Heated

Ford **F-650** Super Duty
For The **BIGGER** Jobs.



CUSTOMER SUPPORT



Roadside Assistance

This 24-hour, seven-days-a-week service is a standard feature on all Ford Commercial Chassis. By dialing 1-800-241-3673, Ford Commercial Truck customers also have access to:

- Flat tire change (requires useable spare tire)
- Battery jump-start
- Fuel delivery, if out of fuel
- Lockout assistance
- Warranty/non-warranty/collision towing
- Winch out

Note: F-650 is eligible for jump start, lockout and towing services.

- Coverage Period:
 - E-Series and F-Series Super Duty (F-250-550): 5-years/60,000 miles, whichever occurs first.
 - F-650/F-750: 2-years/unlimited miles



In-Dealership Service Support

- Approximately 3,500 Ford dealerships in the U.S. and Canada are available to provide service support.
- In-dealership certified service technicians backed by computerized diagnostics and national hotline support
- Dealers provide verification of available owner notification and recall information affecting Ford Commercial Chassis.



Warranty Information

- Ford Commercial Chassis (thru F-550) have a Bumper-to-Bumper limited warranty of 3-years or 36,000 miles, and a Powertrain limited warranty of 5-years or 60,000 miles, whichever occurs first.
- F-650 models have a limited warranty for 2-years and unlimited miles that provides Basic, diesel and Ford drivetrain (axles, drive-shaft and transmission) coverage. See your dealer for F-650 gas engine/transmission warranty details.
- The Power Stroke® diesel engine has a limited warranty of 5-years or 100,000 miles, whichever occurs first.
- Parts of the vehicle manufactured and covered by Ford Motor Company are listed in the Warranty Information Booklet that

comes with the vehicle. It states the vehicle owner's rights and responsibilities, and should be read carefully.

- Non-Ford diesel engines and transmissions are warranted by the manufacturer. Please refer to the manufacturer's limited warranty statement.
- Corrosion Protection – Sheet metal manufactured and installed by Ford is protected against rust through (perforation) for 5-years/unlimited miles for commercial chassis (thru F-550) and 3-years/unlimited miles for F-650.
- See dealer for details.

Ford QVM Program for Shuttle (Transit) Bus Builders

Ford is not only interested in providing safe, high-quality chassis, we also recognize the need for final-stage manufacturers to meet the special vehicle requirements of their customers. To promote reliability and quality of modified Ford products, we publish the Qualified Vehicle Modifier Program guidelines for final stage manufacturers. We also provide technical assistance and assess builder's processes and quality operating systems.

We are proud to work with the best Vehicle Modifiers in the business to complete your personalized fleet requirements. Each one offers a unique lineup of bodies to match your Ford chassis.

- Ameritrans (TMC Group)
 - Champion Bus, Inc.*
 - Coach & Equipment Mfg. Corp.*
 - Collins Bus Corp. (World Trans)*
 - Diamond Coach Corp.*
 - Eldorado National, Inc.*
 - Elkhart Coach*
 - Executive Coach
 - Glaval Bus*
 - Goshen Coach*
 - MicroBird by Girardin*
 - Prime Time Specialty Vehicles, Inc.
 - Starcraft Bus*
 - StarTrans Bus (Supreme)*
 - Tiffany Coachworks
 - Turtle Top*
- * Ford Pool Account



FORD CREDIT
Commercial Lending Services

Ford Credit: Financing That Fits Your Needs

Ford Credit offers finance products to meet the unique financing needs of commercial customers, municipalities and school districts. Ford Credit knows these customers and the commercial lending business and can help deliver the financing products and services that commercial and government customers expect.

<http://credit.ford.com/comlend>

Note: If using biodiesel fuel, Ford recommends biodiesel fuel that is no higher than 20 percent (B20) biodiesel on F-Series Super Duty through F-550 and on F-650 Super Duty. Follow the Special Operating Conditions Maintenance Schedule if using biodiesel.

All incomplete vehicle packages listed in this document require further manufacture and certification by a final stage manufacturer. In addition, Ford urges shuttle (transit) bus manufacturers to follow the recommendations of the Ford Incomplete Vehicle Manual and the Ford Truck Body Builders Layout Book (and pertinent supplements).



Commercial Vehicle Sales & Marketing
North American Fleet, Lease and Remarketing Operations
Ford Motor Company

Information for this publication was correct at the time at which the material was being prepared for printing. Specifications and availability shown are subject to change without notice and Ford Motor Company assumes no liability for such changes.